

# Software Update Flow

Green Series 6000 Treadmill  
CIR-TM6000AC/DC-G version V-1b  
"Newer style with software window"



## 5.3. Software Update

**5.3.1.** Turn OFF the power switch (toggle to 0), pull out the Emergency Stop Key, then remove screw to open the small door on the back of the console, then go thru 2<sup>nd</sup> plastic house opening on the right side: See P1 – P4 pictures

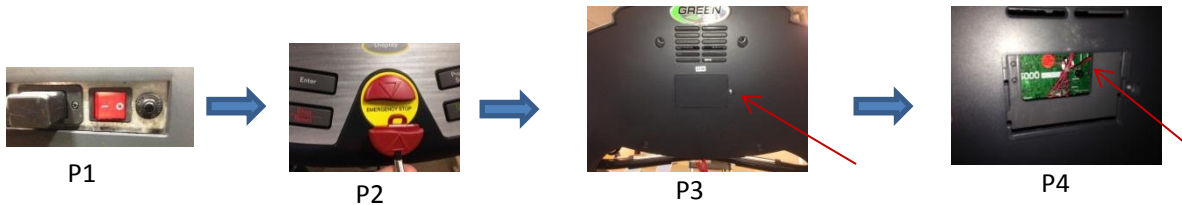

**5.3.2.** Connect the programmer to connector J1 (ISP) of console PCB, right side and center: See P5 & P6 picture

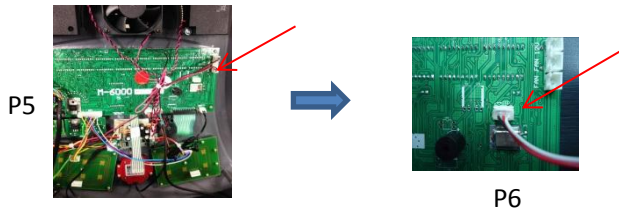

**5.3.3.** Turn ON the power switch (toggle to -): See P7 picture, then press the update button on programmer (USB with cable): See below flow chart pictures.

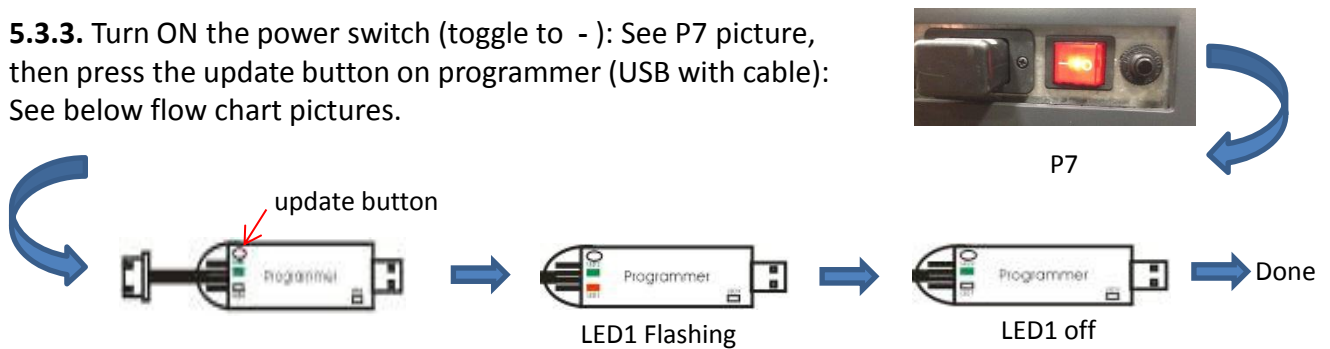

**5.3.4.** Remove the programmer by disconnecting the programmer from connector J1. Re-install the Emergency Stop Key and test unit to confirm updates are correct: See below flow chart pictures.



**5.3.5** Go to Engineering Mode ONE for basic setting 4.1.1 thru 4.1.5 & Engineering Mode FIVE for Quick Start min. age.

**5.3.6** Re-install screws to display then screw to rear housing. DO NOT OVERTIGHTEN. About 10lb. torque per screw into plastic.



# Engineering Mode

Green Series 6000 Treadmill  
CIR-TM6000AC/DC-G version V-1a



## 4.1. Engineering Mode ONE: Basic Settings

Pull out the Emergency Stop Key , press and hold 「Quick Start」 + 「Speed Fast」 and put back the Emergency Stop Key (while depressing the keys). Then release the 「Quick Start」 + 「Speed Fast」 keys. to enter the mode: See below pictures.



**4.1.1. Unit setting** : Message window show 『UNIT - METRIC』 , press 「Speed Fast」 or 「Speed Slow」 or 「Incline Up」 or 「Incline Down」 **change** to 『UNIT - ENGLISH』 , then press 「Enter」 to confirm and to next setting.

**4.1.2. Roller size setting** : Message window show 『ROLLER SIZE 70』 (default=70mm), press 「Enter」 to confirm and to next setting. 6000 Series Treadmill uses

**4.1.3. Motor stop manner** : Message window show 『MOTOR CONTROL』 , press 「Speed Fast」 or 「Speed Slow」 **change** to 『MOTOR FREE』 , press 「Enter」 to confirm and to next setting.

**4.1.4. Min speed setting** : Message window show 『MIN SPEED 0.5』 , press 「Speed Fast」 or 「Speed Slow」 to set the min speed, setting range : 0.2 to 0.7MPH, press 「Enter」 to confirm and to next setting.

*\*note: DC motor treadmill, DO NOT program min. speed less than .5mph*

*\*\*note: AC motor treadmill, DO NOT program min. speed less than .3mph*

**4.1.5. Max speed setting** : Message window show 『MAX SPEED 12.5』 , press 「Speed Fast」 or 「Speed Slow」 to set the min speed, setting range : 5 to 15.5MPH, press 「Enter」 to confirm and back to idle mode.

*\*note: DC motor treadmill, DO NOT program max. speed over 12.5mph*

*\*\*note: AC motor treadmill, DO NOT program max. speed over 15.0mph*

---

## 4.5. Engineering Mode FIVE : Default Age Value Of Quick Start

Press 「Enter」 for 5-8 seconds in idle mode, message window show 『Q-START AGE』 , (default= 40 years old), dot-matrix window show age value, press 「Speed Fast」 or 「Speed Slow」 to set the age, range: 13 thru 80 years old, press 「Enter」 to confirm and back to idle mode.

# Software Update Flow

Green Series 6000 Treadmill  
CIR-TM6000AC/DC-G version V-1a



## 5.3. Software Update

**5.3.1.** Turn OFF the power switch (toggle to 0), pull out the Emergency Stop Key, then remove screws to open the console back, then display screws: See P1 – P4 pictures

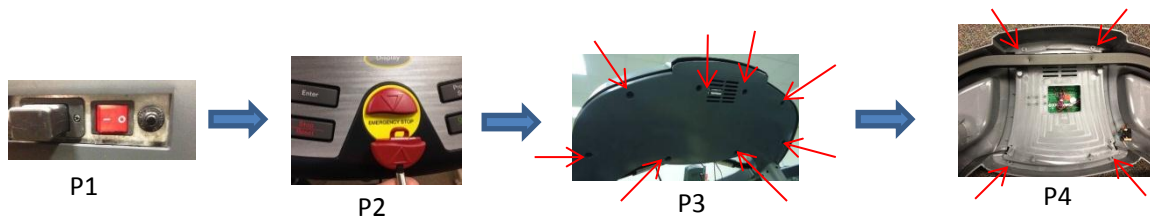

**5.3.2.** Connect the programmer to connector J1 (ISP) of console PCB, right side and center: See P5 & P6 picture

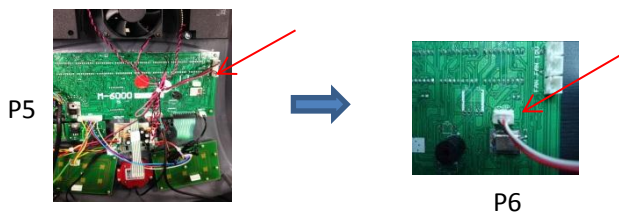

**5.3.3.** Turn ON the power switch (toggle to -): See P7 picture, then press the update button on programmer (USB with cable): See below flow chart pictures.

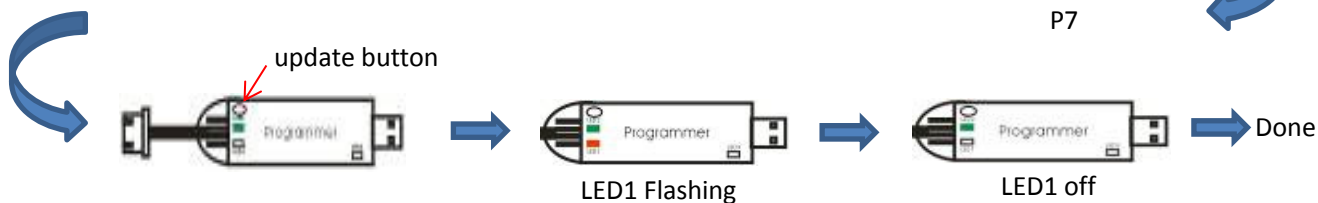

**5.3.4.** Remove the programmer by disconnecting the programmer from connector J1 (ISP). Re-install the Emergency Stop Key and test unit to confirm updates are correct: See below flow chart pictures.



**5.3.5** Go to Engineering Mode ONE for basic setting 4.1.1 thru 4.1.5 & Engineering Mode FIVE for Quick Start min. age.

**5.3.6** Re-install screws to display then screws to rear housing. DO NOT OVERTIGHTEN. About 10lb. torque per screw into plastic.

